

Model: 5ERKM (60 Hz)

4EFRKM (50 Hz)

KOHLER POWER SYSTEMS

Gasoline

9001
KOHLER
POWER SYSTEMS
NATIONALLY REGISTERED

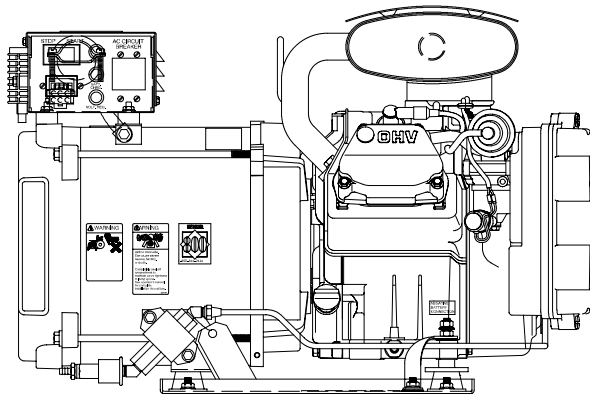

Commercial Mobile Generator Set

Engine Features

- Gasoline fueled
- Four cycle
- Single cylinder, overhead valve
- Air cooled
- Integral 12-volt battery charger
- Solid-state ignition
- Automatic choke
- Integral muffler with heat shield
- Emission compliant

Generator Features

- 6-pin remote control connector
- Class H insulation
- 60/50 Hz field adjustable
- Reconnectable voltage
- Voltage regulation of $\pm 2\%$
- Frequency regulation of $\pm 5\%$
- Lifting eye
- Electric fuel pump
- Single-side serviceability
- RFI suppression
- Captive, vibration-isolation mounting system

Generator Weights and Dimensions

Weight, kg (lbs.), wet	88 (193)
Length, mm (in.)	691 (27.21)
Width, mm (in.)	491 (19.33)
Height, mm (in.)	458 (18.04)

See the drawings on the last page for detailed dimensions.

Generator Ratings

Model Series	Voltage	Hz	25° C (77° F) Amps	25° C (77° F) kW/kVA
5ERKM	120	60	41.67	5.0/5.0
	120/240	60	20.83	5.0/5.0
4EFRKM	110	50	36.36	4.0/4.0
	110/220	50	18.18	4.0/4.0
	220	50	18.18	4.0/4.0

RATINGS: Mobile continuous ratings per ISO 3046, ISO 8528-1, and Kohler ISO rating guideline 2.14. Obtain technical information bulletin (TIB-101) on ratings guidelines for complete ratings definitions.

Availability is subject to change without notice. Kohler Co. reserves the right to change the design or specifications without notice and without any obligation or liability whatsoever. Contact your local Kohler generator distributor for availability.

Application Data

Engine

Engine Specifications	60 Hz	50 Hz
Manufacturer	Kohler	
Model	CS12	
Type	4 Cycle	
Cylinders, number	1	
Displacement, cc (cu. in.)	357 (21.79)	
Bore and stroke, mm (in.)	85 (3.35) x 63 (2.48)	
Compression ratio	8.1:1	
Rated rpm	3600	3000
Max. power at rated rpm, HP	11.5	8
Cylinder block material	Aluminum	
Cylinder head material	Aluminum	
Piston rings	2 compression/1 oil control	
Crankshaft bearings, type	Ball	
Valve material	Stellite-coated exhaust valve	
Connecting rod material	Aluminum	
Governor, type	Mechanical	

Engine Electrical

Engine Electrical System	60 Hz	50 Hz
Ignition	Electronic Magneto	
Starter motor	Bendix automotive type	
Spark plug	Resistor-type RFI suppression	
Battery voltage (DC)	12	
Battery charging	10 amp	
Battery recommendation (min.)	250 CCA	

Fuel

Fuel System	60 Hz	50 Hz
Type	Single-barrel, horizontal carburetor	
Choke	Automatic, electric	
Fuel pump	Electric	
Fuel pump, max. lift, m (ft.)	0.9 (3)	

Fuel Consumption	60 Hz	50 Hz
Gasoline, Lph (gph) at % load		
100%	2.95 (0.78)	2.35 (0.62)
75%	2.54 (0.67)	2.01 (0.53)
50%	2.20 (0.58)	1.67 (0.44)
25%	1.82 (0.48)	1.36 (0.36)

Lubrication

Lubricating System	60 Hz	50 Hz
Type	Splash	
Oil capacity U.S. L (qts.)	2.0 (2.1)	

Operation Requirements

Air Requirements	60 Hz	50 Hz
Engine combustion air requirements m ³ /min. (cfm)	0.5 (19)	0.5 (16)
Generator cooling requirements m ³ /min. (cfm)	2.6 (91)	2.1 (75)

Exhaust

Exhaust System	60 Hz	50 Hz
Exhaust outlet size at hookup, mm (in.)	33.1 (1.3)	
Exhaust gas flow, cfm	59	49

Engine Features

- One-side serviceability of the air cleaner, carburetor, and lubrication system
- Low oil level cutout
- Oil drain valve
- Replaceable air intake filter element
- Electronic fuel pump
- Antidieseling solenoid
- Solid-state ignition
- Integral 12-volt battery charger

Controller Features

- Start/stop rocker switch
- Captive, rubber mounts to isolate vibration
- External 6-pin connector for the remote panel harness
- Hourmeter for scheduling maintenance
- Starter interlock to prevent reengagement of the starter whenever the engine is running
- Plug/receptacle controller connections
- Terminal connections:
 - Clearly identified
 - Corrosion resistant
 - Eliminate the possibility of misconnection

Application Data

Generator Features

- Brushed, rotating field design.
- The rotor and stator are vacuum-impregnated and coated with a high-bond epoxy varnish. The varnish helps prevent corrosion in high-humidity areas.
- The rotor is dynamically balanced to minimize vibration.
- The copper windings ensure minimal heat buildup. The insulation meets NEMA standards for class H insulation.
- Directly connected to the engine, the generator has sealed precision bearing with a precision-machined steel sleeve in the end bracket (or the end bearing tolerance ring) to prevent shaft misalignment and extend bearing life.
- The circuit breaker protects the generator from extreme overload.
- The generator is mounted on a drip-proof tray.
- The generator is equipped with a four-lead reconnectable stator.

Accessories

Remote Start Panel

Allows starting/stopping from a location remote from the generator set. Supplied with a 101 mm (4 in.) connection harness. Overall mounting dimensions are 128 mm (5.04 in.) by 70 mm (2.76 in.) with a minimum mounting depth of 57 mm (2 1/4 in.).

Remote Connection/Extension Harness

Provides additional wiring between all remote panels and the controller connector. One is required for each remote start and meter panel kit. Limit extensions to a total of four kits and 23 m (75 ft.).

12-Inch Remote Wiring Harness

Equipped with a 6-pin connector on one end that is keyed to the controller box connector. Equipped on the other end with pigtailed for connection to a customer-supplied start switch, generator ON light, hourmeter, etc.

Line Circuit Breakers

Protects the generator from extreme overload.

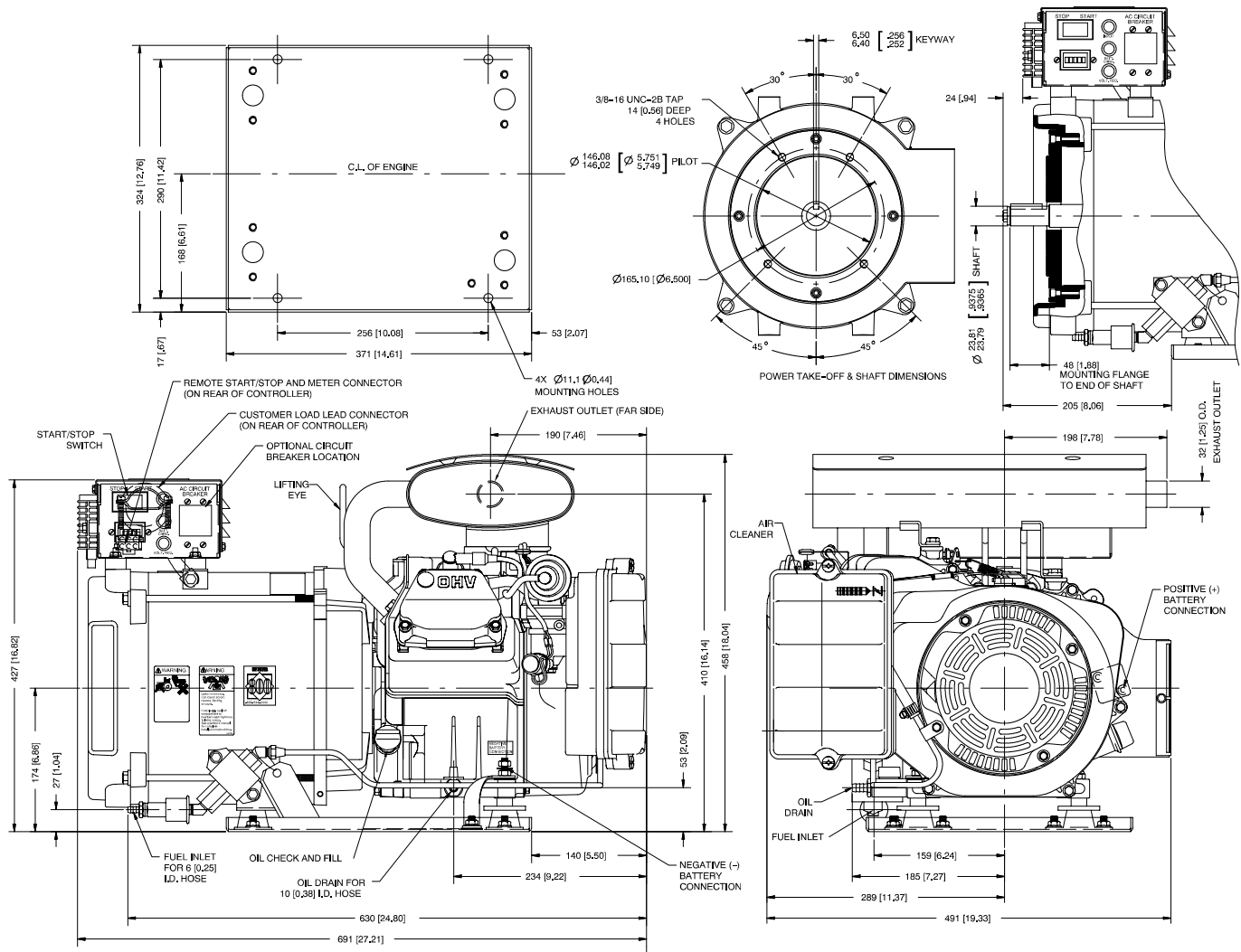

ADV-6537-F

DISTRIBUTED BY:

NOTE: Dimensions in [] are inch equivalents.

NOTE: This drawing is provided for reference only and is not intended for installation planning. Contact your local distributor for more detailed information.

© 2000, 2002, 2003 by Kohler Co. All rights reserved.